

## WATERFLOW DETECTOR

Model VSR-ST

Vane type waterflow alarm switch with retard



### PRODUCT DESCRIPTION

The Model VSR-ST is a vane type waterflow switch for use on wet sprinkler systems that use 1", 1-1/4", 1-1/2" or 2" pipe sizes. It is equipped with a union to accommodate installation in confined spaces.

The unit contains two single pole double throw snap action switches and an adjustable, instantly recycling pneumatic retard. The switches are actuated when a flow of 10 gallons per minute (38 lpm) or more occurs downstream of the device. The flow condition must exist for a period of time necessary to overcome the selected retard period.

### TECHNICAL DATA

<b>Model</b>	VSR-ST
<b>Maximum system pressure</b>	175 psi (12 bar)
<b>Minimum flow rate for alarm</b>	10 gpm (38 lpm)
<b>Maximum surge</b>	18 fps (5,5 m/s)
<b>Enclosure</b>	Die-cast, red powdercoat finish
<b>Contact ratings</b>	Two sets of SPDT (Form C) 10 Amps at 125/250 VAC 2,0 Amps at 30 VDC resistive
<b>Conduit entrances</b>	Two openings provided for 1/2" conduit Individual switch compartments suitable for dissimilar voltages
<b>Usage</b>	Listed plastic, copper and schedule 40 iron pipe. Fits pipe sizes - 1", 1 1/4", 1 1/2" and 2" Note: 12 paddles are furnished with each unit, one for each pipe size of threaded and sweat TEE, one for 1" CPVC, one for 1" CPVC (Central), one for 1" threaded Nibco CPVC, and one for 1 1/2" threaded (Japan)
<b>Environmental limitations</b>	-40°F tot 120°F (4,5°C to 49°C) NEMA 4/IP55 Rated Enclosure – Suitable for indoor or outdoor use with factory installed gasket die-cast housing when used with appropriate conduit fitting
<b>Service use</b>	Automatic sprinkler NFPA-13 One or two family dwelling NFPA-13D Residential occupancy up to four stories NFPA-13R National Fire Alarm Code NFPA-72

## RETARD ADJUSTMENT

The delay can be adjusted by rotating the retard adjustment knob from 0 to the max setting (60-90 seconds). The time delay should be set at the minimum required to prevent false alarms.

Shown with optional Cover Tamper Switch.  
**Do not leave cover off for an extended period of time.**

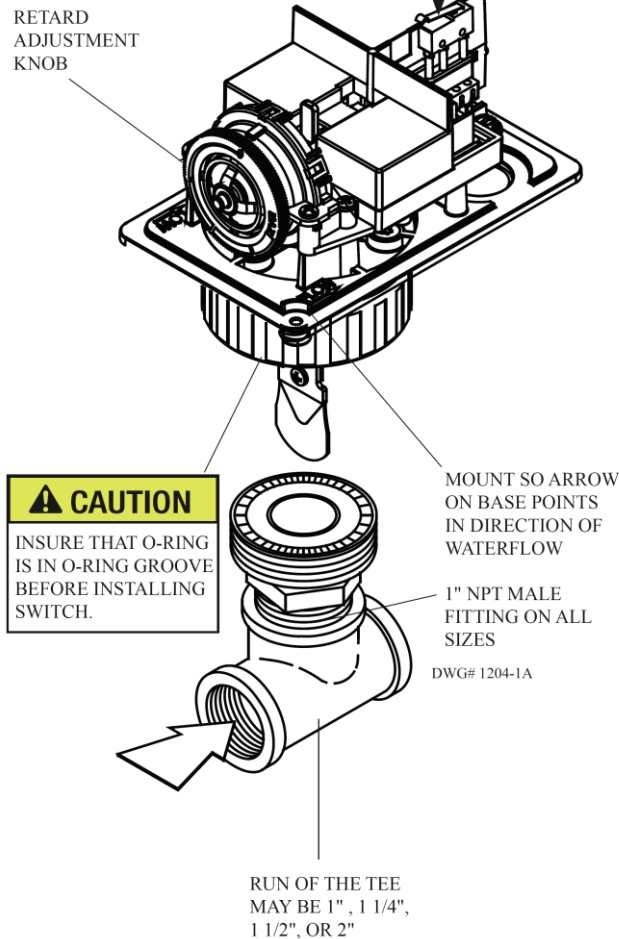

## PADDLE CHANGING

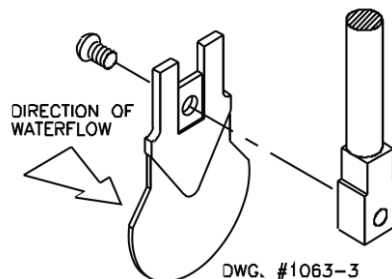

**WARNING:** There are 12 paddles furnished with each unit. One for each size of threaded, sweat or plastic TEE. The paddles have raised lettering that show the pipe size and type of TEE that they are to be used with. The proper paddle must be used. The paddle must be properly attached (see Fig. 3) and the screw that holds the paddle must be securely tightened.

### FITTING

Screw the fitting into the TEE fitting as shown. On sweat TEE's, no threaded bushings, inserts or adapters are permitted unless they comply with the dimensions listed in the chart below.

**Important:** the depth to the inside bottom of the TEE should have the following dimensions:

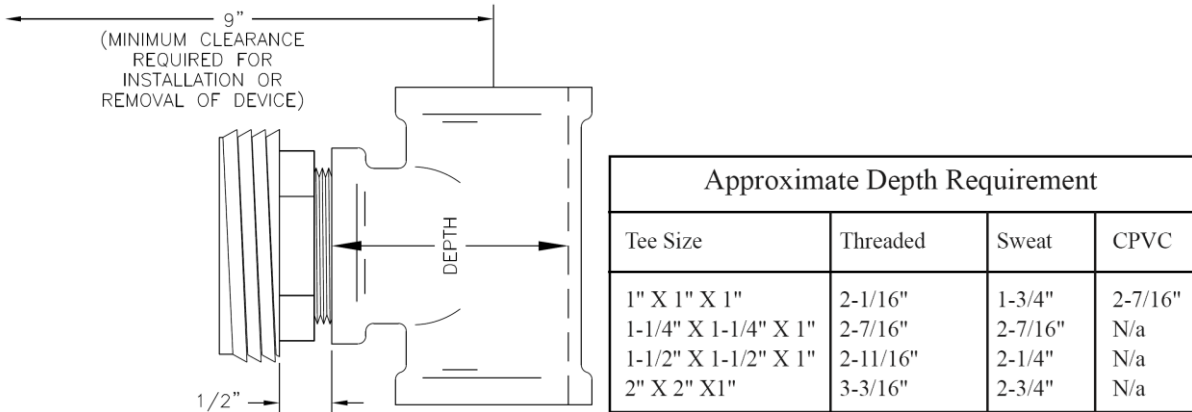

**CAUTION:** To prevent leakage apply teflon tape sealant to the 1" NPT male fitting only. Do not use any other type of lubricant or sealant.

### KNOCKOUT REMOVAL

Break out thin section of cover when wiring both switches from one conduit entrance.

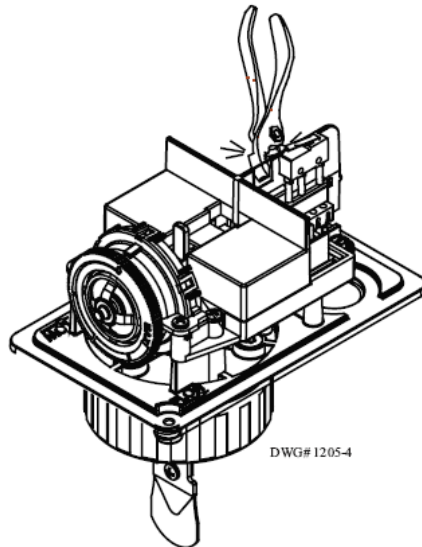

### COVER TAMPER SWITCH

(Shown with cover in place)

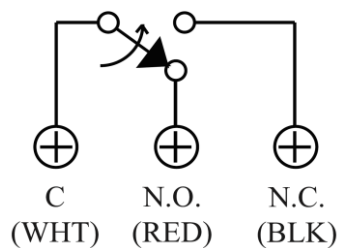

### SWITCH TERMINAL CONNECTIONS CLAMPING PLATE TERMINAL

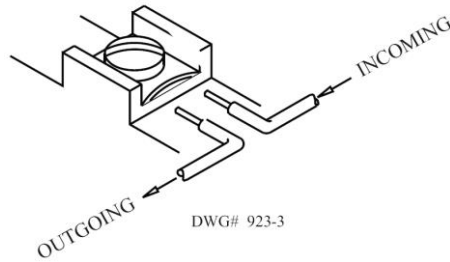

**CAUTION:** An uninsulated section of a single conductor should not be looped around the terminal and serve as two separate connections. The wire must be severed, thereby providing supervision of the connection in the event that the wire becomes dislodged from under the terminal.

### TYPICAL ELECTRICAL CONNECTIONS

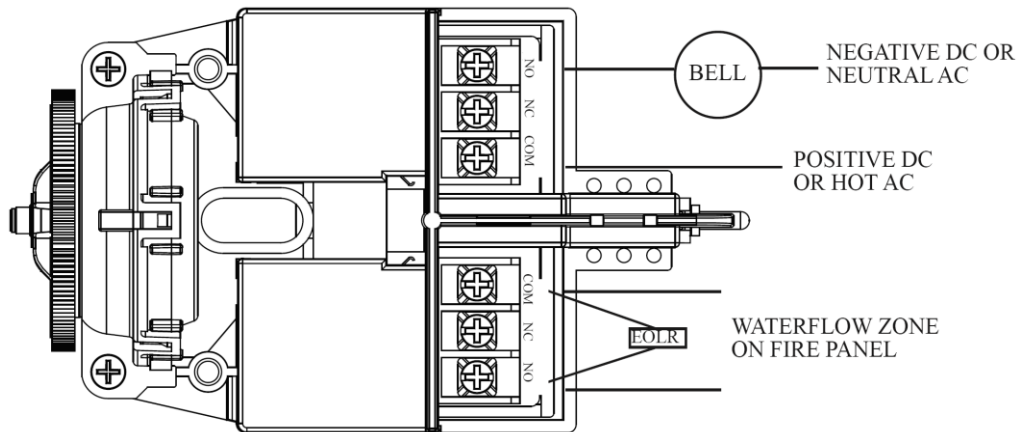

**Notes:**

1. The model VSR-ST has two switches, one can be used to operate a central station, proprietary or remote signaling unit, while the other is used to operate a local audible or visual annunciator.
2. For supervised circuits see "Switch Terminal Connections"

**CAUTION:** Waterflow switches that are monitoring wet pipe sprinkler systems shall not be used as the sole initiating device to discharge AFFF, deluge, or chemical suppression systems. Waterflow switches used for this application may result in unintended discharges caused by surges, trapped air, or short retard times.

### INSTALLATION

These devices may be mounted in horizontal or vertical pipe. On horizontal pipe they should be installed on the top side of the pipe where they will be accessible. The units should not be installed within 6" (15 cm) of a valve, drain or fitting which changes the direction of the waterflow. The unit has a 1" NPT fitting for threading into a noncorrosive TEE.

Select the proper paddle for the pipe size and type of TEE used.

Loosen the union nut and separate the 1" NPT fitting from the VSR-ST. Use no more than three wraps of teflon tape as thread lubricant. Reattach the VSR-ST to the 1" NPT fitting, verifying that the o-ring is properly positioned in its groove. Hand tighten the nut on the union after orienting the device in the appropriate direction to detect waterflow.

CAUTION: Do not over-tighten the union nut, hand tighten only.

The vane must not rub the inside of the TEE or bind in any way. The stem should move freely when operated by hand.

The device can also be used in copper or plastic pipe installations with the proper adapters so that the specified TEE fitting may be installed on the pipe run.

Note: Do not leave cover off for an extended period of time.

## INSPECTION AND TESTING

Check the operation of the unit by opening the inspector's test valve at the end of the sprinkler line or the drain and test connection, if an inspector's test valve is not provided.

If there are no provisions for testing the operation of the flow detection device on the system, application of the VSR-ST is not recommended or advisable.

The frequency of the inspection and testing and its associated protective monitoring system should be in accordance with the applicable NFPA Codes and Standards and/or authority having jurisdiction (manufacturer recommends quarterly or more frequently).

The frequency of inspection and testing for the Model VSR-ST and its associated protective monitoring system should be in accordance with applicable NFPA Codes and Standards and/or the authority having jurisdiction (manufacturer recommends quarterly or more frequently).

If provided, the inspector's test valve, that is usually located at the end of the most remote branch line, should always be used for test purposes.

If there are no provisions for testing the operation of the flow detection device on the system, application of the VSR-ST is not recommended or advisable.

A minimum flow of 10 gpm (38 lpm) is required to activate this device.

## MAINTENANCE

Inspect detectors monthly for leaks. If leaks are found, replace the detector. The VSR-ST waterflow switch should provide years of trouble-free service. The retard and switch assembly are easily field replaceable. In the unlikely event that either component does not perform properly, please order replacement retard switch assembly stock number 1029030. There is no maintenance required, only periodic testing and inspection.

**IMPORTANT NOTICE:** Please advise the person responsible for testing of the fire protection system that this system must be tested in accordance with the testing instructions.

### REMOVAL:

- To prevent accidental water damage, all control valves should be shut tight and the system completely drained before waterflow detectors are removed or replaced
- Turn off electrical power to the detector, then disconnect wiring.
- Loosen union nut and separate unit from the glued in fitting.
- Gently lift the unit far enough to get your fingers under it. With your fingers, roll the vane so it will fit through the fitting while continuing to lift the waterflow detector.
- Lift detector clear of pipe.

## ORDERING INFORMATION

SIZE	CODE
From 1" DN25 to 2" DN50	DFVSRST025050

Specify:

Model	
Quantity	

## AG FIRE SPRINKLER

AG Fire Sprinkler offers a wide selection of components. Then a list of products is presented by AG Fire Sprinkler, we can offer all these components, made with precision to protect people, anywhere, anytime.

- Sprinklers
  - Standard Coverage
  - Extended Coverage
  - Storage
  - Dry
  - Accessories
  
- System Valves
  - Wet
  - Dry
  - Preaction Equipment
  - Accessories
  
- Spray System Open Nozzles
  - High Velocity Nozzles
  - Medium Velocity Nozzles
  - Window Nozzles
  - Hydrosield Nozzles
  - Mushroom Type Nozzles
  
- Foam equipment
  - Tanks
  - Proportioners
  - Foam Discharge Equipment
  - Foam Concentrates
  
- Deluge equipment for Water Spray and Foam
  - Clapper Deluge Valves
  - Diaphragm Deluge Valves
  
- Monitors
  - Manual Monitors
  - Remote Monitors
  - Monitor Nozzles
  - Towers and Trolleys
  
- Valves
  - Butterfly Valves
  - Gate Valves
  - Check Valves
  - Pressure Control Valves
  - Test and Drain
  - Hose, Hydrant and Fire Connection Valves
  - Fire Department Connections

The equipment presented in this data sheet is to be installed in accordance with the latest published Standards of the national fire protection association (NFPA), FM Global, LPCB, VdS or other similar organizations, also with the provisions of governmental codes or ordinances whenever applicable. This documentation is not contractual. AG Fire Sprinkler reserves the right to any kind of change without notice.