

BLADDER TANK

Model AG-TMI

Proportioning Bladder tank As per PED/CE

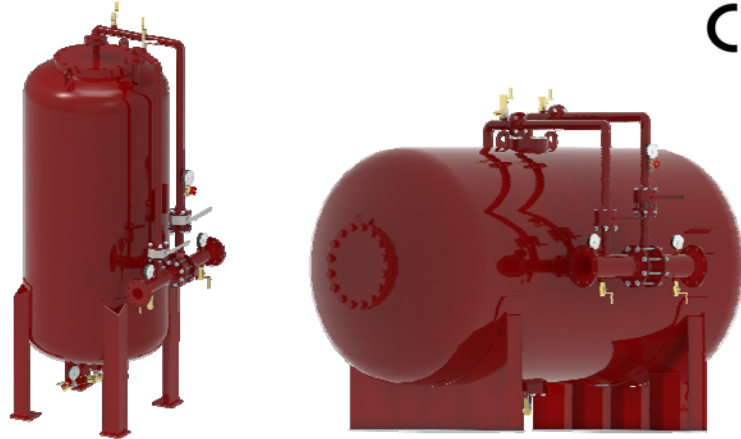

PRODUCT DESCRIPTION

The Bladder Tank Foam Proportioning System model AG-TMI is available in vertical or horizontal mounting. It uses water pressure to inject foam concentrate into water supply and automatically proportions foam concentrate. This system does not require a foam concentrate supply pump.

The system is supplied with pressure vessel, bladder, fill and drain valve for water and foam concentrate, ratio controller and vent valve. Optionally it can be supplied with foam concentrate control valve. The valve allows concentrate flow only when minimum of 2,1 bar (30 psi) water pressure is established in the system.

TECHNICAL DATA

Model	AG-TMI
Concentrate Storage Capacity	For Vertical Tank 500 to 15.000 lt (132 to 3963 gal) For Horizontal Tank 1.000 to 10.000 lt (264 to 2642 gal)
Maximum Working Pressure	12 bar (175 psi)
Test Pressure	18 bar (260 psi)
Design Temperature	-10°C to 50°C (14°F to 122°F)
Tank Mounting Type	Vertical or Horizontal
Vessel Construction	Carbon Steel as per PED/CE, for unfired pressure vessels
Finish	Red RAL 3000

OPERATION

Once the main water flow is established and water inlet and foam outlet valves are opened, the water enters the area between vessel wall and bladder, applying pressure to the bladder. The foam concentrate is forced out of the bladder through the foam concentrate outlet pipe and into the ratio controller through metering orifice. The concentrate pressure and water inlet pressure at ratio controller will be same, as the main water supply pressure is utilized to expel the foam from the bladder. The water flowing through the ratio controller jet creates a low pressure area common both to downstream water and foam concentrate. This injects the concentrate in to the ratio controller through an accurate sized orifice proportioned to water venturi. This ensures correct proportioning over a wide range of flow condition.

In bladder system, the bladder is used as diaphragm to separate the water and foam concentrate within the tank. The foam concentrate is injected into the ratio controller using water pressure.

DIMENSIONS: VERTICAL BLADDER TANK

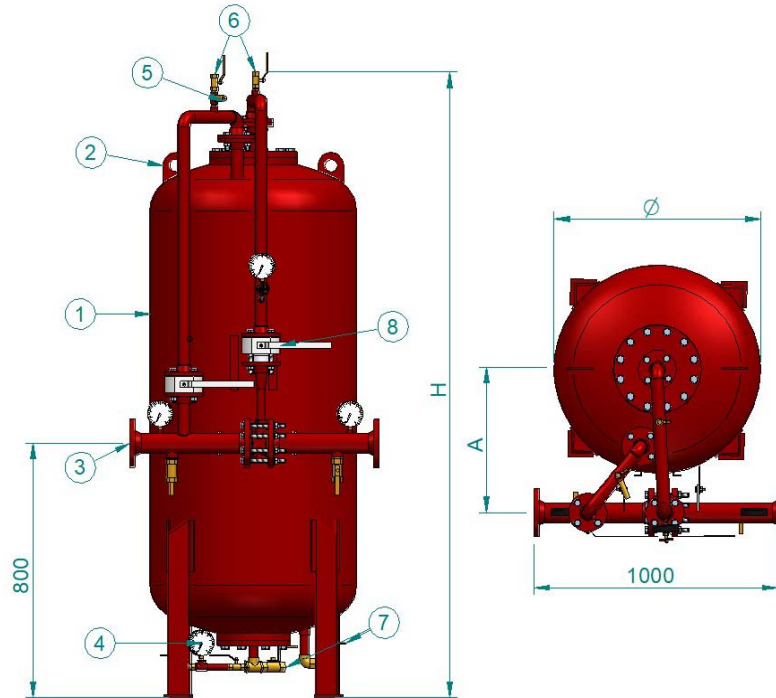

CAPACITY (lt)	DIMENSIONS (mm)			MAX EMPTY WEIGHT (kg)
	H	Φ	A	
200	1945	500	450	267
300	1625	700	550	280
400	1895	700	550	314
500	1910	810	660	430
600	2125	810	660	460
800	2525	810	660	520
1.000	2225	1020	770	525
1.500	2800	1020	770	630
2.000	3060	1120	820	850
2.500	3280	1120	820	930
3.000	3345	1280	870	1145
3.500	3380	1370	910	1245
4.000	3440	1460	940	1315
4.500	3700	1460	940	1420
5.000	3550	1610	1040	1480
5.500	3720	1610	1040	1555
6.000	3600	1760	1160	1600
7.000	4000	1760	1140	1765
8.000	3890	1980	1140	2140
9.000	3795	2100	1300	2668
10.000	3845	2200	1350	2826
11.000	3975	2200	1350	2929
12.000	4245	2200	1350	3125
15.000	5145	2200	1350	3743

DIMENSIONS: HORIZONTAL BLADDER TANK

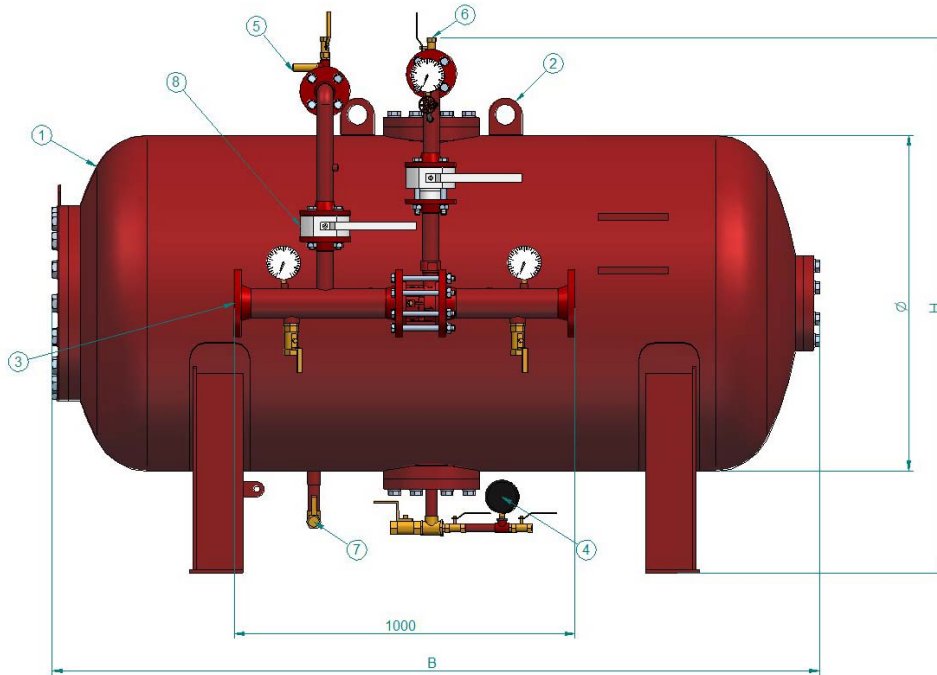

CAPACITY (lt)	DIMENSIONS (mm)			MAX EMPTY WEIGHT (kg)
	H	Φ	B	
1.000	1610	990	1655	625
1.500	1605	990	2265	720
2.000	1710	1110	2530	980
2.500	1780	1160	2755	1100
3.000	1880	1280	2845	1200
3.500	1970	1350	2875	1550
4.000	2070	1460	2930	1580
4.500	2070	1460	3195	1650
5.000	2220	1610	3005	1720
6.000	2370	1740	3100	1940
7.000	2370	1740	3450	2125
8.000	2580	1950	3220	2260
9.000	2715	2110	3310	2840
10.000	2815	2190	3370	3045

COMPONENTS

ITEM	COMPONENTS	MATERIALS
1	Bladder tank	Carbon steel + Hypalon
2	Lifting hook	Carbon steel
3	Proportioner	Steel
4	Level gauge	Stainless Steel
5	Safety valve	Brass
6	Air vent	Brass
7	Drain valve	Brass
8	Foam nozzle	Stainless Steel

INDUCTOR

SIZES	DIMENSIONS (mm)			MAX EMPTY WEIGHT (kg)
	FLANGE (ANSI)	FLANGE (DIN)	PIPE	
3" – DN80	3" RF #150	DN80 – PN16	3" Sch.40	35
4" – DN100	4" RF #150	DN100 – PN16	4" Sch.40	44
6" – DN150	6" RF #150	DN150 – PN16	6" Sch.40	68
8" – DN200	8" RF #150	DN200 – PN16	8" Sch.40	92
10" – DN250	10" RF #150	DN250 – PN16	10" Sch.40	170
12"- DN300	12" RF #150	DN300 – PN16	12" Sch.40	245

SIZES	FLOW RATE (lpm)	INDUCTOR HOLE Ø (mm)	ΔP (bar)
3"	1980	56	0.98
4"	3120	70	0.93
6"	8325	115	0.95
8"	14850	145	0.85
10"	24920	185	0.90
12"	49785	250	0.95

PIPE SIZE	EXTERNAL DIAMETER (mm)	WALL THICKNESS (mm)	INTERNAL DIAMETER (mm)
3"	88,9	5,49	77,92
4"	114,3	6,02	102,26
6"	168,3	7,11	154,08
8"	219,1	8,18	202,74
10"	273	9,27	254,46
12"	323	9,52	303,96

Note: The above data have suggested by AG FIRE SPRINKLER to obtain best performance of the mixer.
All requested different data will be engineered by AG FIRE SPRINKLER to optimize the performance.

PRESSURE LOSS

2 1/2" Mixer

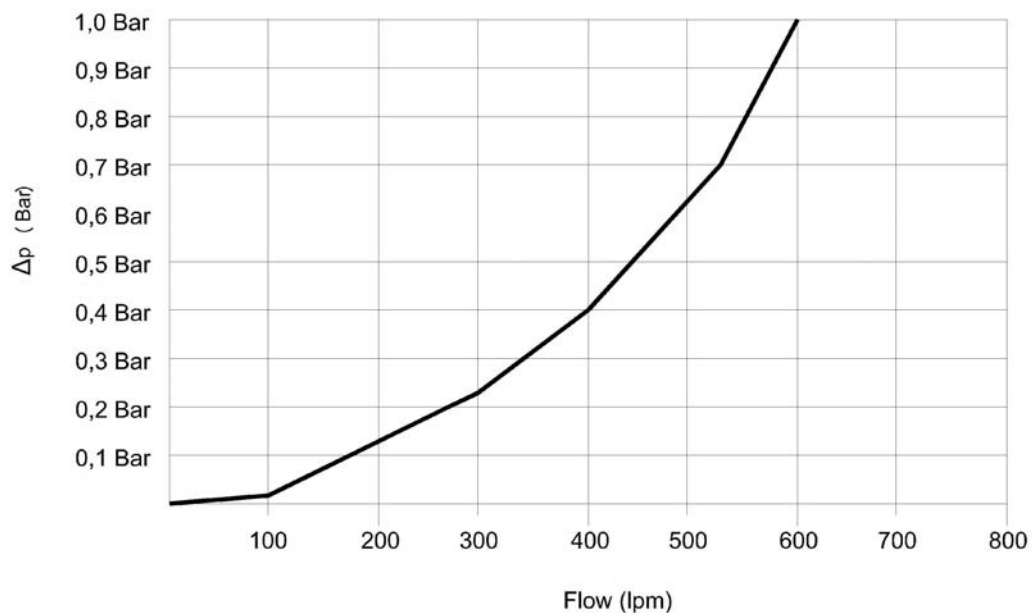

3" Mixer

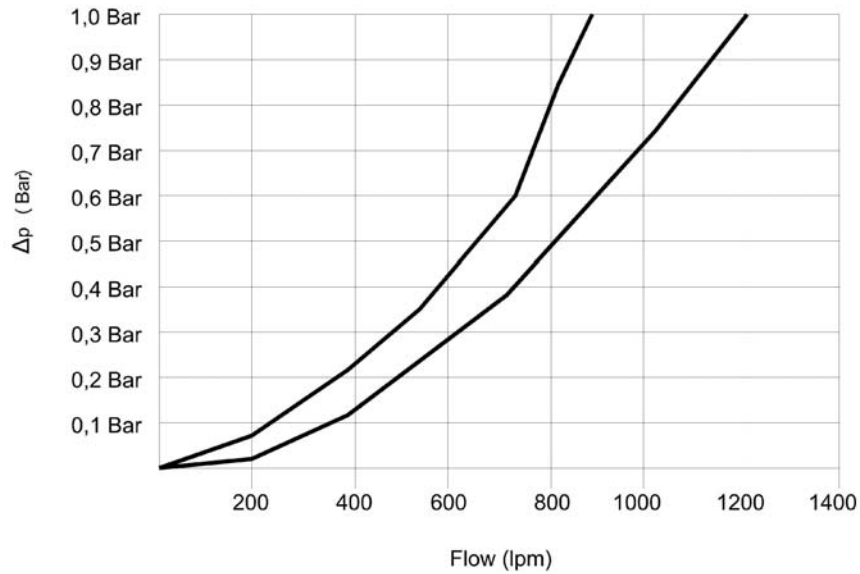

4" Mixer

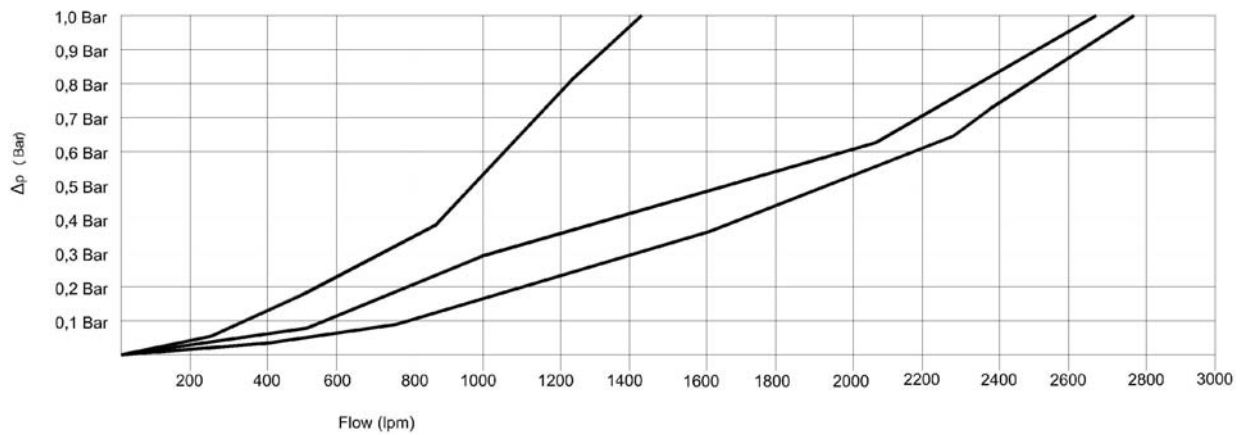

6" Mixer

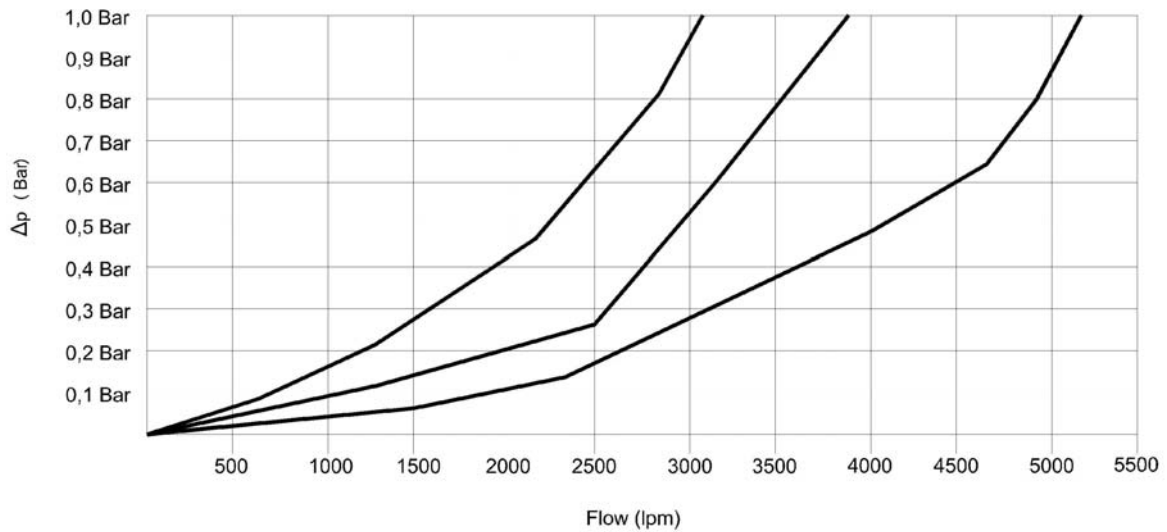

8" Mixer

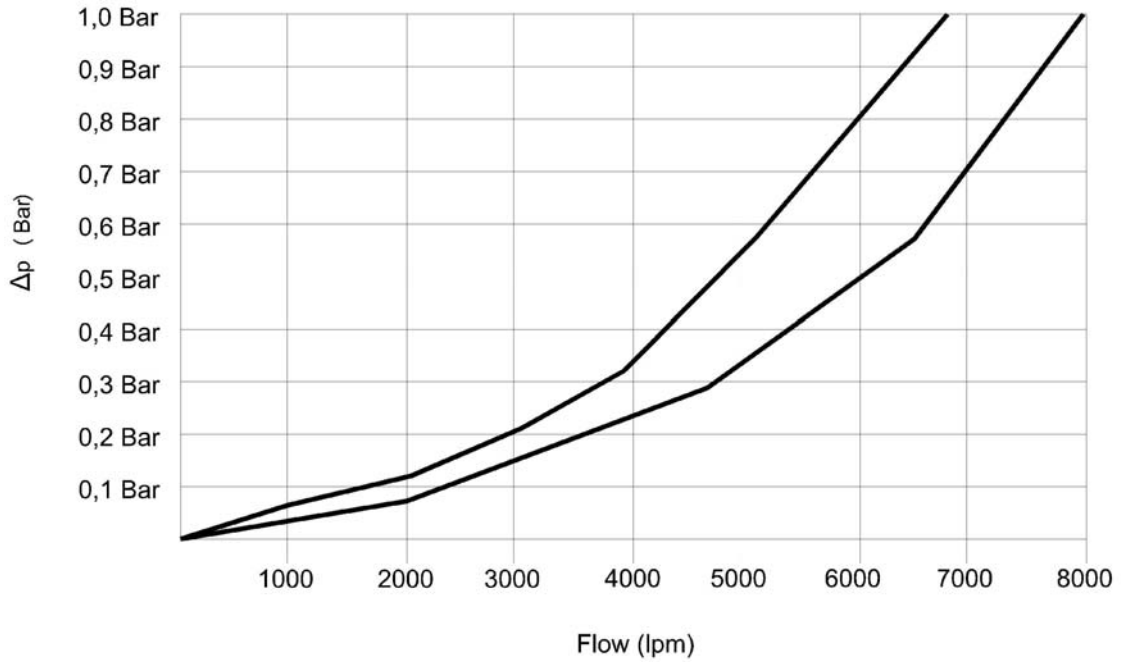

10" Mixer

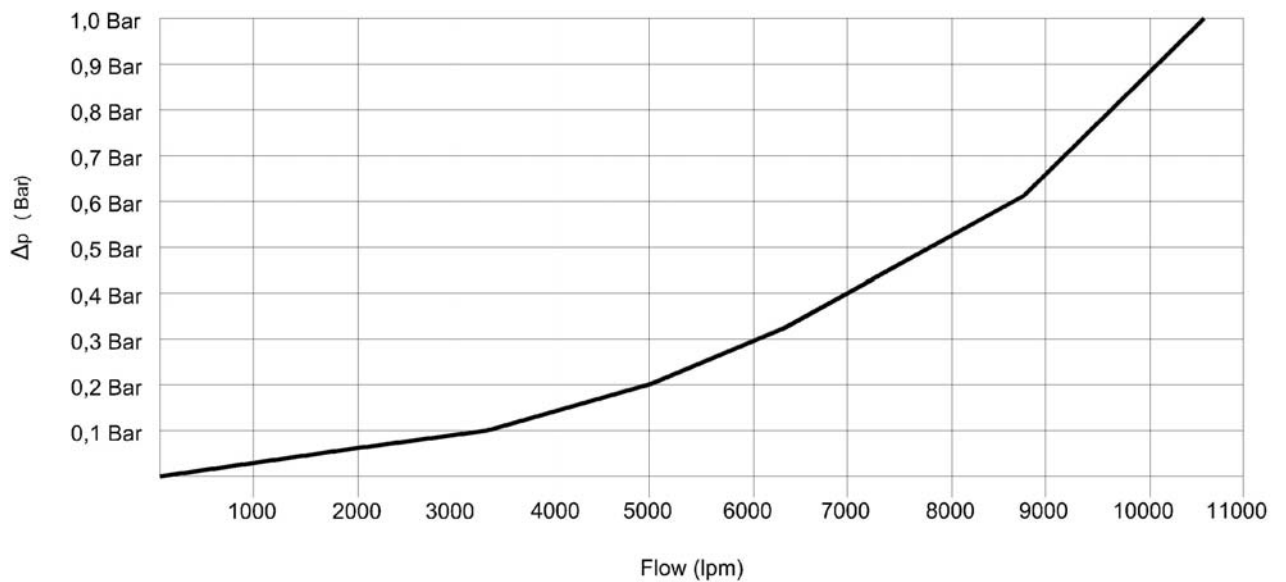

INSTALLATION, TESTING AND MAINTENANCE

An installation, testing and maintenance manual is provided with the equipment. The bladder tank must be installed, inspected and tested by a qualified and trained person.

After few initial successful test, a trained person must inspect and test the system. It is recommended to carry out physical inspection of the system regularly. The system must be fully tested at least once in a year or in accordance with applicable NFPA codes or in accordance to the standard of the organization having local jurisdiction.

The owner is responsible for maintenance of the inductor in proper operating condition.

It is advisable to leave enough space around the tank, free of walls or other obstacles, for connecting the foam system piping and supports.

ORDERING INFORMATION

CAPACITY	POSITION		
	VERTICAL	HORIZONTAL	DOUBLE VERTICAL
200 Lts	FDM00200V		The double vertical tank's capacity is for each tank
300 Lts	FDM00300V		
400 Lts	FDM00400V		
500 Lts	FDM00500V		
600 Lts	FDM00600V		
1.000 Lts	FDM01000V	FDM01000H	FDM01000DV
1.500 Lts	FDM01500V	FDM01500H	FDM01500DV
2.000 Lts	FDM02000V	FDM02000H	FDM02000DV
2.500 Lts	FDM02500V	FDM02500H	FDM02500DV
3.000 Lts	FDM03000V	FDM03000H	FDM03000DV
3.500 Lts	FDM03500V	FDM03500H	FDM03500DV
4.000 Lts	FDM04000V	FDM04000H	FDM04000DV
4.500 Lts	FDM04500V	FDM04500H	FDM04500DV
5.000 Lts	FDM05000V	FDM05000H	FDM05000DV
6.000 Lts	FDM06000V	FDM06000H	FDM06000DV
7.000 Lts	FDM07000V	FDM07000H	FDM07000DV
8.000 Lts	FDM08000V	FDM08000H	FDM08000DV
9.000 Lts	FDM09000V	FDM09000H	FDM09000DV
10.000 Lts	FDM10000V	FDM10000H	FDM10000DV
FP01200RPF03	Foam solution loading manual pump		

Specify:

Tank type	
Storage capacity	
Quantity	
Size of proportioner	
Flow	
Pressure	
Type of foam concentrate to be used	
Percentage of induction required	

AG FIRE SPRINKLER

AG Fire Sprinkler offers a wide selection of components. Then a list of products is presented by AG Fire Sprinkler, we can offer all these components, made with precision to protect people, anywhere, anytime.

- Sprinklers
 - Standard Coverage
 - Extended Coverage
 - Storage
 - Dry
 - Accessories
- System Valves
 - Wet
 - Dry
 - Preaction Equipment
 - Accessories
- Spray System Open Nozzles
 - High Velocity Nozzles
 - Medium Velocity Nozzles
 - Window Nozzles
 - Hydroshield Nozzles
 - Mushroom Type Nozzles
- Foam equipment
 - Tanks
 - Proportioners
 - Foam Discharge Equipment
 - Foam Concentrates
- Deluge equipment for Water Spray and Foam
 - Clapper Deluge Valves
 - Diaphragm Deluge Valves
- Monitors
 - Manual Monitors
 - Remote Monitors
 - Monitor Nozzles
 - Towers and Trolleys
- Valves
 - Butterfly Valves
 - Gate Valves
 - Check Valves
 - Pressure Control Valves
 - Test and Drain
 - Hose, Hydrant and Fire Connection Valves
 - Fire Department Connections

The equipment presented in this bulletin is to be installed in accordance with the latest published Standard of the National Fire Protection Association, Factory Mutual Research Corporation, or other similar organizations and also with the provisions of governmental codes or ordinances whenever applicable. This documentation is not contractual. AG Fire Sprinkler reserves the right to any kind of change without notice.
